

Solutions that connect

Application technology

Innovative methods
for battery gluing

Production quality extends the life span of batteries

Safe energy for the mobility of tomorrow

Precise application of glues, sealants and fillers in battery production

The battery is the heart of an electric vehicle. For end customers, it is one of the decisive arguments for buying one. Its long life span, performance and safety therefore influence the success of e-mobility to a large degree. As the market for fully electric and hybrid vehicle grows, so battery production is also gaining in importance.

COMPLETE PROVIDER FOR BATTERY GLUING

Dürr offers a complete solution in the application technology for battery gluing. A modular system for the application of glues, sealants and fillers in battery production delivers high quality, flexibility, and adaptability for various viscosities and mixing ratios. In addition, Dürr develops innovative processes for the application of thermally conductive materials in the area of thermal management.

Dürr technology is variably configurable from the processing of small quantities in the laboratory to prototype construction and pre-series, to large-volume processing in the course of series production.

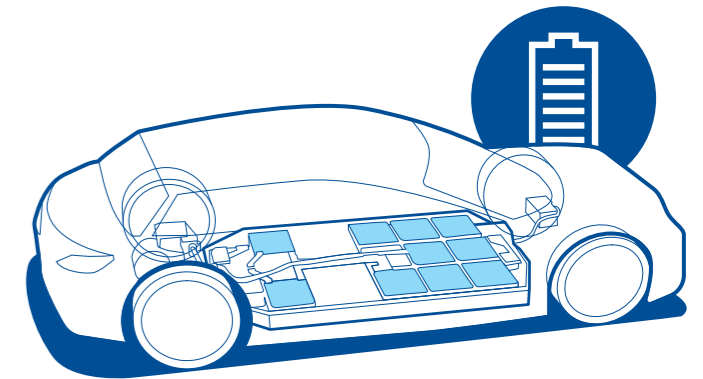

100%

The modular Dürr system for battery gluing promises flexibility

Dürr test center for battery gluing

As an international partner of the automotive industry, Dürr is represented with test centers specifically for battery gluing in Southfield (USA), Shanghai (China), Ulsan (Korea) and Bietigheim-Bissingen (Germany). Entirely in the spirit of production efficiency, we offer a special service here in the form of test procedures that ensure the smooth and optimized start of production in your battery plant.

SERVICES IN THE TEST CENTERS:

- Processes and components are tested nearing series production and under real conditions
- Development of customer-specific solutions
- Processes are optimized without affecting ongoing production
- Risks before production start are greatly reduced
- Process development



From the cell to the battery box

Safety and quality in the application

Battery gluing is subject to the most stringent of requirements, as the sensitive battery cells in particular must be secured in the event of a collision. Essential for this is a precise application process that ensures an even distribution of the adhesives and sealing compounds and thus protects the cells against vibrations. A complete seal without air inclusions guarantees optimal thermal conductivity, prevents humidity from entering, and gases produced from escaping. This increases not only

the level of safety but also the life span of the entire battery. Moreover, the application technology has to work robustly and with high quality, because abrasive materials are used in the presence of high flow rates. The material flow must also be constantly temperature controlled at all times in order to ensure the precise dosing quantities and to avoid damaging the temperature-sensitive battery cells.

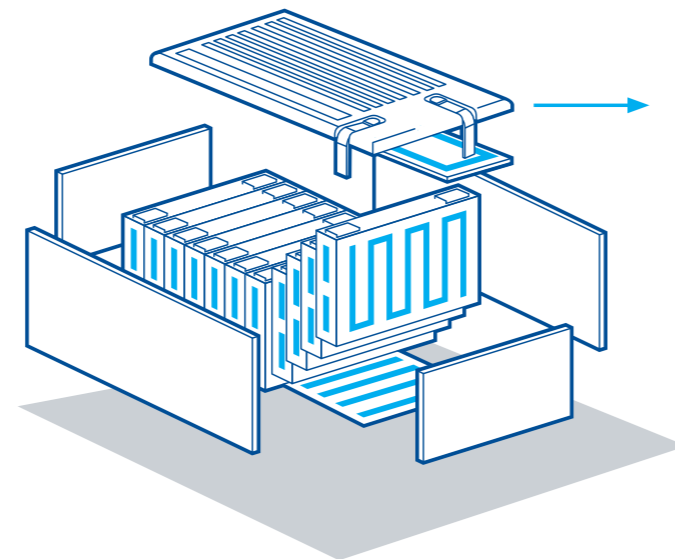

GLUING THE BATTERY CELLS

The use of precise applicators enables the highly sensitive cells to be glued into modules without being damaged. The elastic 2K thermally conductive glue protects the cells against knocks and overheating.

OVERALL COMPETENCE IN BATTERY GLUING

As a provider, Dürr combines its amassed application expertise for the gluing and sealing of automobile batteries. We optimize processes and technologies in close dialog with our customers. In this way, we develop future solutions together that adapt specifically to the requirements of battery production.

EXPERTISE IN EVERY GLUING AND SEALING PROCEDURE, INCLUDING THE NECESSARY PRETREATMENT AND CLEANING



EXPERTISE IN EVERY GLUING AND SEALING PROCEDURE, INCLUDING THE NECESSARY PRETREATMENT AND CLEANING

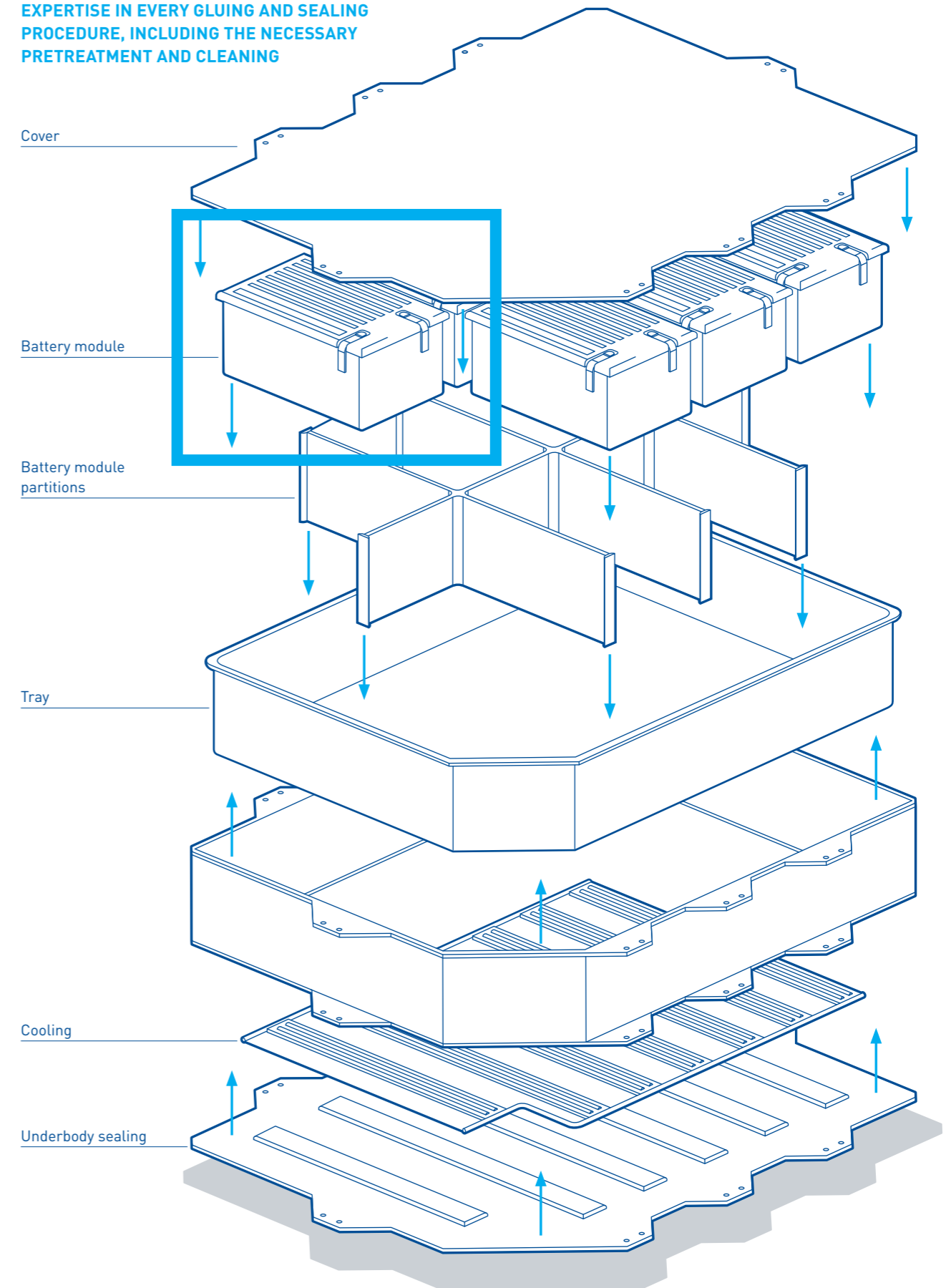

Plant layouts

Modular assembly for the application

Each gluing and dosing application from Dürr is individually tailored to your requirements. The layout of the plant can be executed in a range of sizes for different types of application. Both unheated and heated variants are available. These ensure that viscous glues and sealants can be pumped and dispensed. The mixing process of the 2K glue can also be

adapted to the desired application. We also supply matching materials ranging from small containers/cartridges (20–200 liters) to large containers (1,000 liters) to central material supply systems. From individual components to the engineering of the overall system.

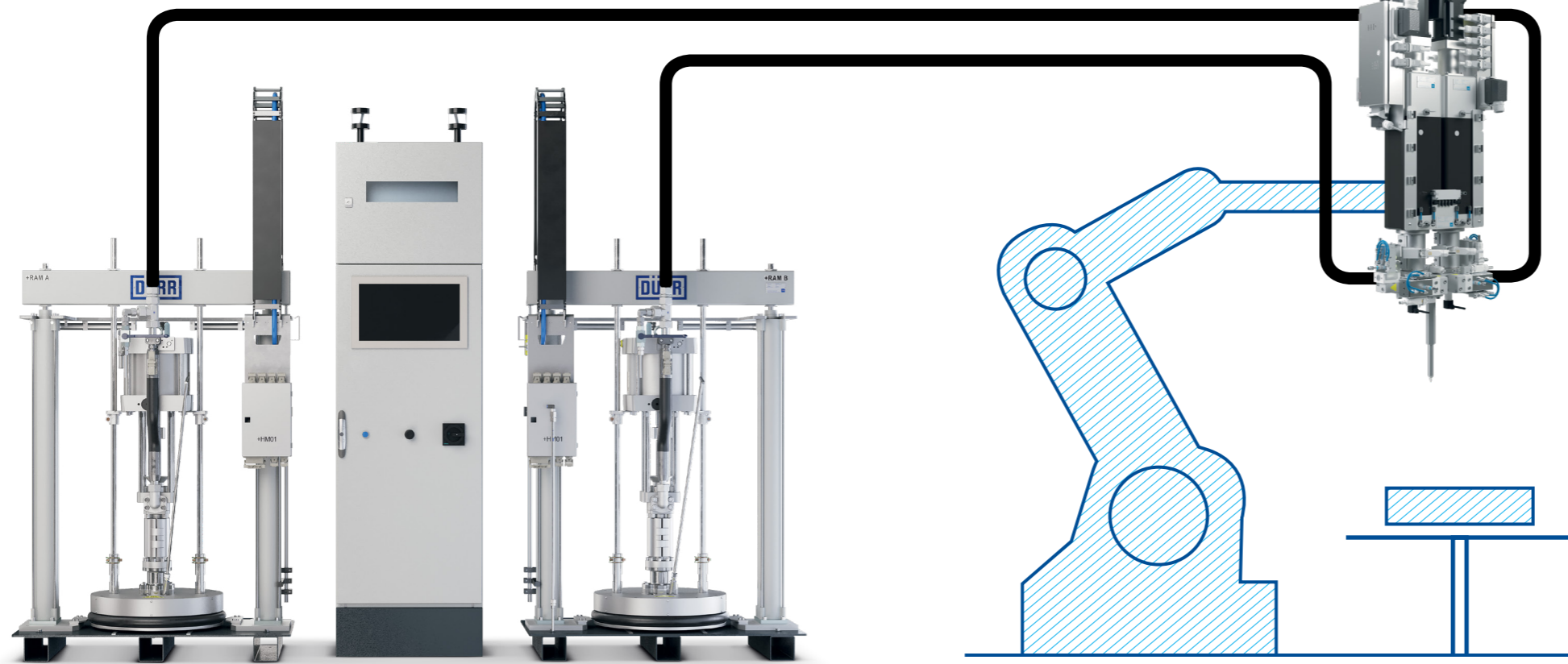

Material supply (EcoRAM)

The **EcoRAM** is a drum press for use with all of Dürr's gluing machines. Both unheated and heated/temperature-controlled variants are available. These ensure that viscous glues can be pumped and dispensed. The system can be designed as a single or double drum pumping station.

Control system

The **EcoHVMP** consists of a modular, extendable control cabinet with standard components for controlling the pumps and applicators. The space-saving control (Safety PLC) makes do without complex and expensive cable guides. Plug connectors provide for rapid electrical and pneumatic installation. The **EcoHVC** software developed at Dürr has numerous analytical tools and is I4.0 compatible.

Dosing systems

The electric piston dosing unit **EcoShot Meter** doses high-viscosity materials regardless of the influences of the material supply. It is suitable for applications that require very high dynamism and precision in the process. The control is fully integrated into the **EcoHVC** and, as a double dosing unit, enables an infinite application of the material or a 2K application.

Application technology

for battery systems

Dürr application technology ensures a reproducible process and constant seam quality. It is robust and withstands the abrasive materials at high flow rates. This contributes to the maximum availability of the plant and greater production efficiency.

EcoShot METER 150

Weight: 85 kg
Volume: (net) 2 × 150 cm³
Flow rate: 0.1–28 cm³/s

EcoShot METER 2-COMPONENT

Weight: 90/170/250/180 kg
Volume: 150/300/600/150–600 cm³
Flow rate: 0.1–50 cm³/s



EcoHVC APPLICATION CONTROL

- Modular process software
- Online data recorder with up to 15 signals
- Maintenance assistant and trend detection

EcoPumpVPS FOR ABRASIVE MEDIA

Container: 20–200 l
Max. supply volume: 500 cm³/DH
Max. pressure: 360 bar

LEADING IN PRODUCTION EFFICIENCY



Dürr Systems AG
Carl-Benz-Strasse 34
74321 Bietigheim-Bissingen
Germany



Subject to change. The information in this brochure contains only general descriptions and performance features, which may vary in specific cases of application.
The desired performance features are only binding if they have been agreed upon explicitly at the conclusion of the contract. © Dürr 2021