



EcoBell2 SL DC

Rotary atomizer direct charge

N34150004

EcoBell2 SL is an electrostatic charged, state of the art rotary atomizer. Unique design and high transfer efficiency make this device to the perfect choice for everyone who is requiring top quality results. The very fine and smooth atomization is suitable even for the highest quality requirements and is moreover characterized by a transfer efficiency that is typically way higher than for pneumatic atomizers. Water-borne, solvent-borne as well as UV-paints can be processed, no matter if they contain metallic flakes or not.

CUSTOMER BENEFITS



- [High paint flow rate](#)
- [Maximum application efficiency](#)
- [Transfer efficiency of up to 95% possible](#)
- [Suitable for application on machines and robots](#)
- [Quick-change technology](#)
- [Optimized bell disk purging](#)
- [Dual shaping air system](#)
- [Automatic paint tube centering](#)
- [Modular design for economic maintenance](#)
- [Tested according to Dürr quality standards](#)
- [ATEX Ex II 2G T4 with Dürr equipment](#)
- [ATEX Ex II 3G T4 without Dürr equipment.](#)



Technical datasheet

EcoBell2 SL DC

N34150004

CHARACTERISTICS

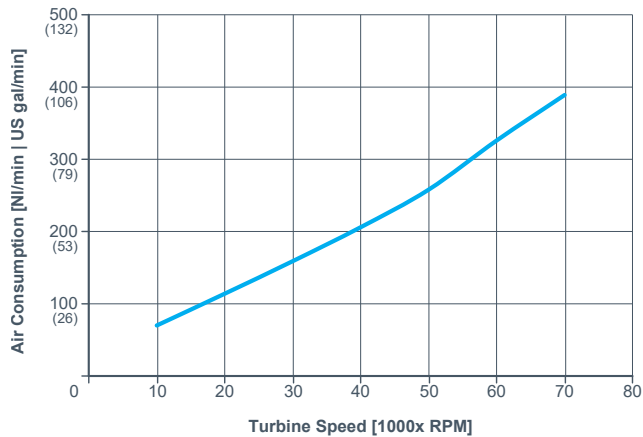

Turbine speed / Air consumption – No Load

TECHNICAL ILLUSTRATION

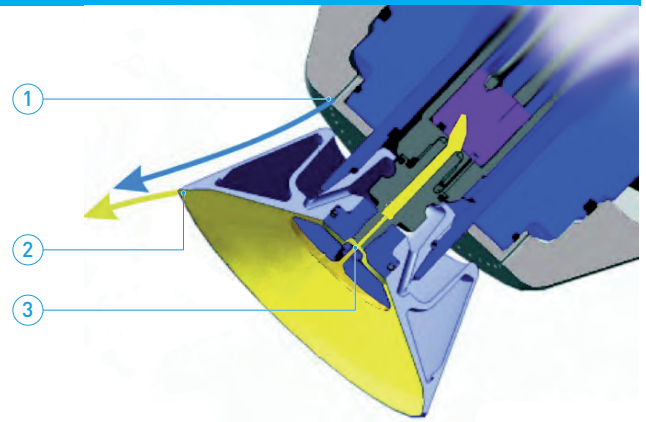

1 Shaping air flow, 2 Paint atomization, 3 Paint supply

SPECIFICATION

Weight	4 500 g
Diameter Electrode Ring	165 mm (6.5")
Length Atomizer	229 mm (9")
Air Pressure max. (dyn.)	8 bar (116 psi)
Air Pressure min. (dyn.)	6 bar (87 psi)
Solids Diameter max.	5 µm
Spray Distance	220 mm (8.7")
Recom. Spray Speed	0.2 - 0.6 m/s
Speed Range	8 000 - 70 000 rpm
Recom. Speed Range	15 000 - 55 000 rpm
Flow Rate Fluid max.	700 ml/min. (11.1 gal/h)
Recom. Flowrate Fluid, min.	80 ml/min (5.55 gal/h)
Recom. Flowrate Fluid, max.	350 ml/min (5.55 gal/h)
Fluid Pressure Inlet max.	20.0 bar (290 psi)
Air Consumption Turbine, min.	100 NI/min (3.5 sft3/min)
Air Consumption Turbine, max.	730 NI/min (25.8 sft3/min)
Air Consump. Motor Bearing	50 NI/min (1.8 sft3/min)
Consump. Shaping Air 1 max.	520 NI/min (18.4 sft3/min)
Consump. Shaping Air 2 max.	480 NI/min (17.0 sft3/min)
Recom. Consump. Shaping Air	100-350 NI/min (3.5-12.4 sft3/min)
Viscosity max.	180 mPas
Rel. Humidity max.	65 ±5 %
Constant Current	5 - 50 µA
High Tension	80 kV
ATEX Marking	Ex II 2G T4

Bell disc to be ordered separately. Solids diameter acc. to ISO 8573.1-2010 1-4-1 Technical values may vary depending on paint material, paint flow rate, bell speed and operation mode.

Technical datasheet

EcoBell2 SL DC

N34150004

ACCESSORIES

Part No.	Description
E09060504	Connection cable flange package HT 5m
N34850039	Add-on unit atomizer EB2-DA/KUKA
E09060505	Connection cable flange package HT 10m
W02020315	Installation MONTAGE GEHÄUSE EcoBell
M24010343	Clamping piece 61x60x45 D20,1 Al
W02100109	Set of install. tools f.N34150002/4/6 DA
N32500026	Mixer cpl.extern atomizer D6,35 L310
W12600006	Tool f.cleaning EcoBell2 Thread M18x1

Part No.	Description
N34850018	Add-on unit atomizer WAR RP 60° with loc
W50020096	Case cpl.f.HT checking device EN50176
N44050010	Atomizer seat L140 EcoBell
N65040001	Hand earthing stick
W02020187	Installation tool Assembly Cover EcoBell
W02020255	Installation tool Assembly EcoBell2
W02100112	Set of installation tools f.N34150004 DA
W12600018	Special cutter f.cleaning EcoBell2 Threa

SPARE PARTS

Part No.	Description
N32030056	Control valve EcoBell2 SL DC
M30010274	Union nut M86x2 L33 EcoBell2
M16040099	Atomizer housing cpl. EcoBell2 SL HX
M11080215	Intermediate flange EcoBell2 SL HX
E09400059	Fibre optic cable f.rpm meas. EcoBell2
M09020145	Nozzle d1,1 M6x0,75 external purge SST
D79910016	Countersunk bolt M5x20 DIN7991 8.8 Z St
N34960003	Repair kit f.WAR control valve
N34960004	Repair kit paint pipe 1K o RF
N34960006	Repair kit for N21010139/0152/0153
N34960007	Repair kit for N21010139/152/153 LLR
N34960009	Repair kit for N32030056 1K o RF
N34960011	Repair kit for M16040099
N34960010	Repair kit for N21010139/0152/0153 FFKM

Part No.	Description
N34960012	Repair kit for N34770091/2/115/6 1K o RF
N34960013	Repair kit F.N16010064/65/N16310020/21
N34960016	Repair kit for N34850018
N34960017	Repair kit f.mixer N32500026
N16310020	Bell disk D52 O.R.VS-D40 EcoBell2
N16310021	Bell disk D52 GR0,4 VS-D40 EcoBell2
N34770091	Flange Package EcoBell2 SL WAR EWS L5m
N34770092	Flange package EcoBell2 SL WAR EWS L10m
M09020143	Nozzle d0,7 M6x0,75 external purging SST
M09020144	Nozzle d0,9 M6x0,75 external purging SST
W40130192	Hose recirculation VH
W40130193	Hose recirculation S - VHS
W40130194	Hose recirculation L - VHL